

Cut the grille



Cut the grille as shown above on both sides. This will give you an opening of 56,5 cm to fit the LED bar with brackets. Cut the horizontal spokes close to the profile.

Fasten the brackets to the lamp



Notice that there is one left and one right bracket.

Install the brackets to the lamp before installing on the vehicle. Use loctite on the screws. Leave it just loose enough to be able to adjust the height after installation. Do not over tighten, as this may crack the bracket.

Secure the lamp with the screw

Install the lamp with the brackets on to the car. Drill a 2 mm hole and insert the provided screw.



Adjust the lamp

The lamp can be tilted up and down. It's important to complete this step, or you may experience less light performance.



Adjust the light up and down, so the light shines all the way to the end of an alley without the light stopping into the road. It should shine all the way through.



Wiring tips

The lamps should use a DT relay harness SKU: 14730 And it should be connected as shown below.

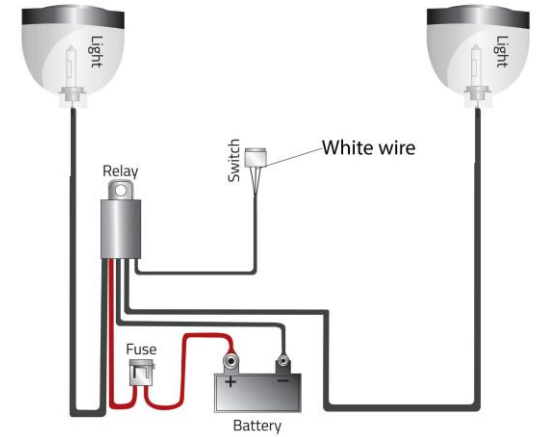

Most of us want to control the lamps with the car's light switch. In such case, disconnect the white wire from the relay harness' switch and connect this white cable to the car's high beam signal.

Alternative wiring

Control the relay with the vehicle's high beam signal

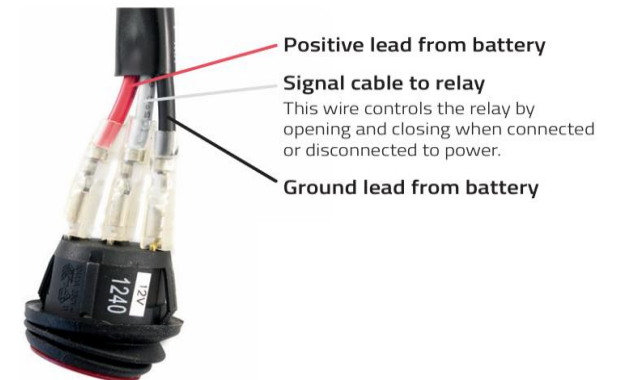

Supplied switch with relay harness.

Canbus signal

Many cars require a Can adapter for a high beam signal. If you are unable to find or measure a 12v high beam signal in your lamp, check out your options with CanM8, XBB or Modernum from your supplier.

For this particular car we can recommend using Modernum MO651200 because it saves about 1 hour. Because the LED-bar is so powerful it is recommended to use the Modernum as a signal provider and use a relay harness (14730) as the main provider of power to the LED-bar. In such case connect the Modernum output to the white signal cable on the relay harness (14730).

The can high/low wires are found on the driver side lamp main connector. Follow the instructions on Modernums website and download the correct software for your car there.



LUMEN

Grille kit for light integration

Toyota Rav4 Hybrid

(Not Plugin Hybrid)

147102



For video instructions scan this with your phone and follow the link

